

## Specifications

MODEL		GTH™-4013 SX	
MEASUREMENTS		Metric	Imperial
Lifting height maximum with stabilisers	12.99 m	42 ft 7 in	
Lifting height maximum without stabilisers	12.80 m	42 ft	
Lifting capacity maximum	4,000 kg	8,818 lbs	
Lift capacity at maximum height	3,000 kg	6,614 lbs	
Lift capacity at maximum reach	1,250 kg	2,756 lbs	
Forward reach maximum	9.08 m	29 ft 9 in	
Reach at maximum height	1.30 m	4 ft 3 in	
<b>A</b> Height	2.40 m	7 ft 10 in	
<b>B</b> Height at steering wheel	1.60 m	5 ft 3 in	
<b>C</b> Width	2.32 m	7 ft 7 in	
<b>D</b> Cab width	93 cm	3 ft	
<b>E</b> Track	1.92 m	6 ft 4 in	
<b>F</b> Wheelbase	2.95 m	9 ft 8 in	
<b>G</b> Length at front wheels	4.79 m	15 ft 9 in	
<b>H</b> Length at fork-holder plate	6.06 m	19 ft 11 in	
<b>I</b> Ground clearance	39 cm	1 ft 3 in	
<b>J</b> Overall width, stabilisers extended	2.89 m	9 ft 6 in	
<b>M1</b> Obstruction angle	40°	40°	
<b>M2</b> Departure angle	46°	46°	

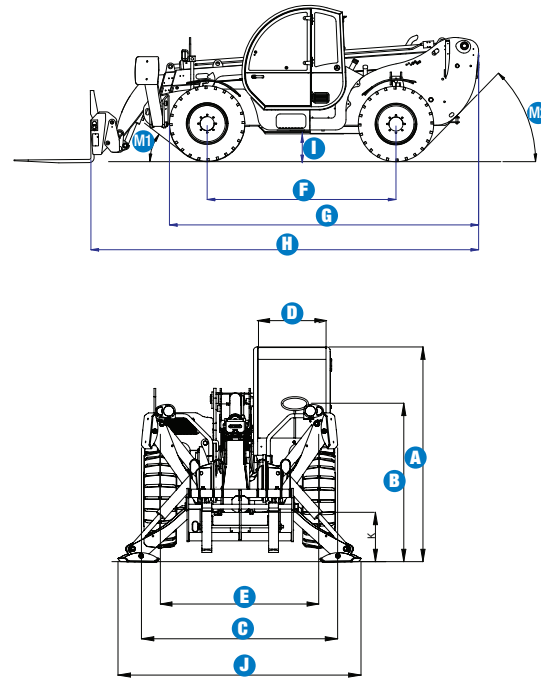

PRODUCTIVITY	
Inside/outside turning radius	2.42 m/4.65 m      8 ft 1 in/15 ft 3 in
Break-out force (with 800 L shovel SAE J 732/80)	6,000 kg      13,228 lbs
Towing capacity at dynamometer*/**	3,590 kg/4,105 kg      7,914 lbs/9,050 lbs
Drive speed max.	28 km/h      17 mph
Fork-holder plate rotation	138°      138°
Chassis levelling on front axle	+/- 7°      +/- 7°
Floating forks	L 1,200 mm      L 3 ft 11 in Section 120 x 50 mm      Section 5 in x 2 in
Tyres (DIN 70361)	405/70 20" PR14 8 holes wheel disc
Lifting/lowering speed**	11 sec./7 sec.      11 sec./7 sec.
Extension/retraction speed**	17 sec./11 sec.      17 sec./11 sec.

POWER	
Engine	Perkins 1104 D-44T Turbo diesel 74 kW (99 hp), Tier 3
Tank capacities	
Petrol	135 L      30 gal
Engine oil	7 L      1.5 gal
Hydraulic oil	150 L      33 gal

SOUND LEVEL	
Sound pressure level (operator position)	83 dB (LpA)      83 dB (LpA)
Guaranteed sound power level	103 dB (LwA)      103 dB (LwA)

VIBRATION LEVEL	
Vibration level hand-arm system	<2.5 m/s <sup>2</sup> <8 ft 2 in/s <sup>2</sup>
Vibration level whole body	0.23 m/s <sup>2</sup> 9 in/s <sup>2</sup>

WEIGHT	
Weight***	9,850 kg      21,715 lbs

STANDARDS COMPLIANCE	
EU Machinery Directive 2006/42/EC	
Operating cab conforms to ISO3471 (ROPS) and ISO3449 (FOPS)	
Low emission engine conforms to EU Directive 97/68/EC stage III	
2000/14/EC EU Directive (noise)	

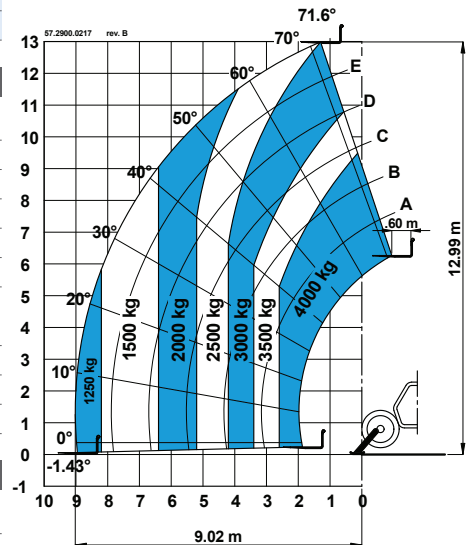

Lift capacity chart (with stabilisers)

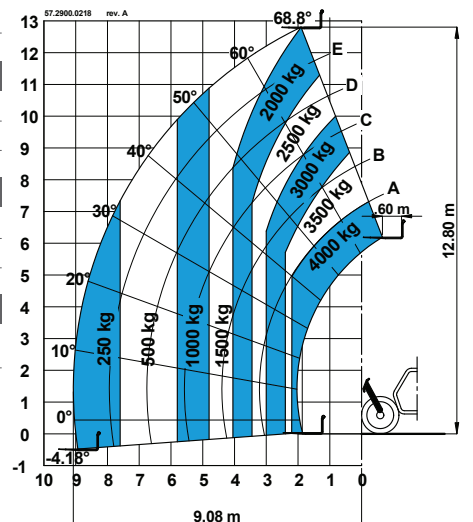

Lift capacity chart (without stabilisers)

\*Max. load, \*\*Without load  
\*\*\* Weight will vary depending on options and/or country standards

# Features

## STANDARD FEATURES

### MEASUREMENTS

- 4,000 kg (8,818 lb) maximum lift capacity
- 12.99 m (42 ft 7 in) maximum lift height
- 9.08 m (29 ft 9 in) maximum forward reach

### PRODUCTIVITY

- 4 x 4
- 4 - wheel steer
- 3 steering modes:
  - front wheel steer
  - crab steer
  - coordinated steer
- Hydraulic line on boom
- Power assisted steering
- Front stabilisers
- Hydrostatic transmission with variable displacement pump and motor
- Mechanical 3x1 joystick
- Limited slip differential on front axle
- Chassis levelling on front axle +/- 6°
- Floating forks
- Attachment holder plate with mechanical coupling
- Two-section door (glass upper/steel lower)
- Angle and length indicators on boom correspond to load charts
- Adjustable suspended seat with operator detection seat switch
- Battery disconnection switch
- Large diameter steering wheel
- Front & rear windscreen wipers
- Sunshield
- Roof protection grid
- Two side rear view mirrors
- Front & rear lights
- Side mounted engine for easy access to components
- Oil immersed, multi-disc brakes on rear axle
- Lockable fuel tank
- Longitudinal stability control system :
  - Load moment indicator with LEDs
  - Audible alarm
  - Automatic lock-out of boom extension and lowering
  - Automatic lock-out of stabilisers
  - Automatic lock-out of rear axle
- Maintenance collar
- Hydraulic inching
- Road/Jobsite switch

### POWER

- Perkins turbo diesel 99 hp (74 kW), Tier 3

### TYRES

- 405/70-20" PR14. 8 holes wheel disc (DIN 70361)



## OPTIONS & ACCESSORIES

### PRODUCTIVITY

- Air conditioning
- Second hydraulic line on boom + electric line on boom
- Hydraulic quick coupling for attachments
- Concrete mixing bucket pre-arrangement
- Hydraulic Jib / Winch pre-arrangement on boom
- Windshield protection grid
- Adjustable spotlight on boom including cable reel and cable bracket
- Adjustable spotlight on cab
- Fish eye rear view mirror in the back
- Wiper on cab roof
- Spare wheel 405/70-24"PR14 (instead of standard tyres)
- Foam filled tyre 405/70-20"PR14 (Supplement)
- Rear wheels alignment sensor
- Biodegradable naturelle HF-E Shell oil
- 6-ton towing hitch
- Hydraulic parking brake kit

### ATTACHMENT OPTIONS

- Spare wheel 405/70-20" PR14
- Spare wheel 405/70-24" PR14
- Foam filled spare wheel 405/70-20" PR14
- Loading shovel 800 L
- Concrete bucket 500/800 L manual/hydraulic discharge
- Concrete mixing bucket 500 L with remote control
- Brick-holder basket
- 10-ton hydraulic jack and 24 mm wheel nut wrench
- FEM 3 plate and forks kit
- Fork side-shift (+/- 100 mm)
- Fixed hook on plate
- 2 m jib, 2,000 kg capacity
- 4 m jib, 900 kg capacity
- 4 m jib with 900 kg capacity hydraulic winch
- Hydraulic winch 3000 kg

### Enquiries from Europe:

Tel: +31 165 519 361  
Fax: +31 165 511 148  
Email: AWP-InfoEurope@terex.com

### Offices:

#### France

Tel: +33 (0)2 37 26 09 99  
Fax: +33 (0)2 37 26 09 98

#### Germany

Tel: +49 (0)4221 491 810  
Fax: +49 (0)4221 491 820

#### Spain

Tel: +34 93 572 50 90  
Fax: +34 93 572 50 91

#### Scandinavia

Tel: +46 31 57 51 00  
Fax: +46 31 57 51 04

#### The Netherlands

Tel: +31 165 519 361  
Fax: +31 165 511 148

#### UK

The Maltings  
Wharf Road  
Grantham NG31 6BH  
UK  
Tel: +44 (0)1476 584333  
Fax: +44 (0)1476 584334

#### Middle East

Tel: +971 4 399 0381  
Fax: +971 4 399 0382  
Email: AWP.Infome@terex.com

### Corporate Headquarters:

#### Genie United States

18340 NE 76th Street  
P.O. Box 97030  
Redmond, WA  
USA 98073-9730  
Tel: +1 425 881-1800  
Fax: +1 425 883-3475

### Distributed By: