

# MANISCOPIC

## ■ MT 932



- Lifting height : 9.00 m
- Capacity : 3200 kg
- Maximum forward reach : 6.58 m
- Torque convertor
- 4 wheel steer - 4 wheel drive

 **MANITOU**

# MT 932

**Lifting capacity** .....3200 kg  
 at 500 mm from forks heels.  
 Tipping load  
 at maximum reach : .....673 kg  
 Tear out force with bucket  
 to ISO 8313.....7400 daN

**Lifting height** : .....9.00 m  
**Times** : unladen / loaded (in s)  
 Lifting .....6.7/7.3  
 Lowering .....5/4.7  
 Simultaneous extension 1st and 2nd booms .12.2/13.3  
 Simultaneous retraction 1st and 2nd booms.....8/7.6  
 Time unladen (in s)  
 Crowd .....2.8  
 Dump .....2.3

**Tyres**  
 400/80 - 24 TL 156 B

**Forks** (mm)  
 Length.....1200  
 Width x thickness.....125 X 45  
 Maximum distance between forks.....1040  
 Carriage rotation.....126°

**Multidisc brakes - hydraulically assisted on both axles**

**PERKINS Engine**  
 Type .....1104D-44T  
 Capacity.....4 cyl. 4400 cm<sup>3</sup>  
 Power at 2200 rpm : .....70 kW/95 HP  
 (ISO/TR 14396)  
 Maximum torque : .....392 Nm at 1400 rpm  
 Direct injection  
 Water cooling

**Transmission**.....Torque Convertor  
 Electro - Hydraulic reversing shift  
 4 speeds forward and reverse  
 Maximum travel speed.....25 km/h

**Hydraulics**  
 Lifting/tilting pump  
 gear type : .....240 bars/105 l/mn  
 Flow divider with priority to steering and brakes.

**Capacities**  
 Cooling system .....18.5 l.  
 Engine oil.....10.5 l.  
 Hydraulic oil .....125 l.  
 Transmission oil .....15.5 l.  
 Fuel tank .....120 l.

**Weight unladen** (with forks) .....7640 kg  
**Overall width** .....2.26 m  
**Overall height** .....2.30 m  
**Turning radius** (outside wheels) .....3.68 m  
**Overall length** .....4.71 m  
**Ground clearance** .....0.44 m  
**Drawbar pull**.....8400 daN

## Reach at maximum height : 2.35 m

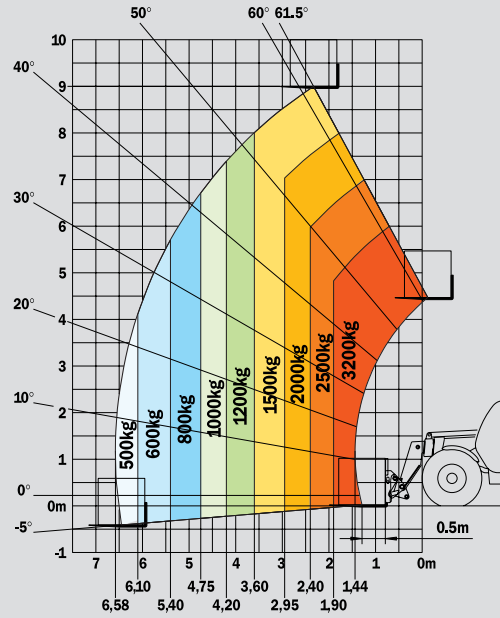

Under prEN 1459 annexe B

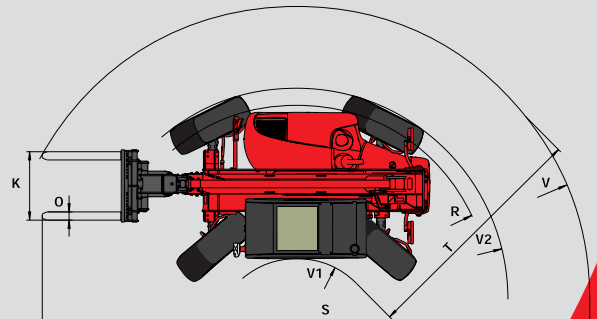
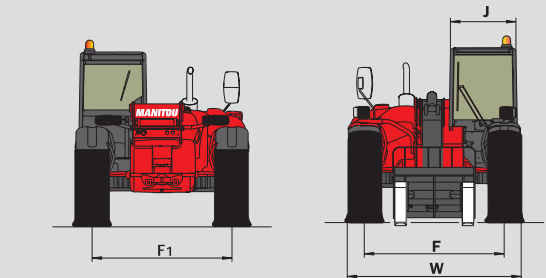
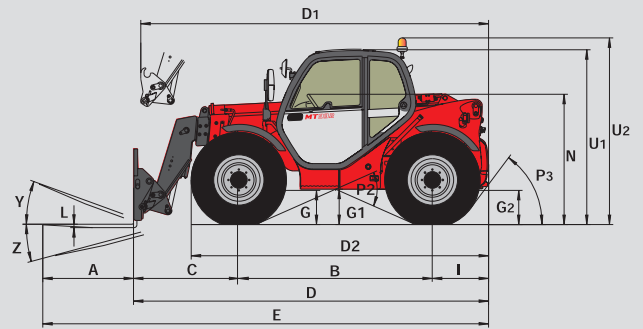

A	1200
B	2560
C	1393
D	4716
D1	4811
D2	3908
E	5916
F	1846
F1	1846
G	455
G1	440
G2	440
I	763
J	865
K	1040
L	45
N	1690
O	125
P2	47.5°
P3	53°
R	3460
S	7541
T	3510
U1	2300
U2	2550
V	4760
V1	1250
V2	3668
W	2261
Y	11.9°
Z	113.7°

mm

This publication in no way constitutes an offer and the company reserves the right to alter specification without prior notice.  
 The MANITOU models presented in this brochure can be supplied complete with optional equipment attachments.

